

APPLICATION NOTE NO. 22

“LABEL” YOUR APPLICATION SOLVED

APPLICATION:

Label sensing of all types, size and colors of labels, even clear on clear.

ULTRASONIC SOLUTIONS:

For most standard, rectangular labels use:		For irregular-shaped labels use:	
SM6X7A-A08-01	1.5" range, 0.5" span, N.O. outputs	SM6X7A-A08-02	1.5" range, 0.5" span, N.O. outputs
SM6X7A-A08-11	1.5" range, 0.5" span, N.C. outputs	SM6X7A-A08-12	1.5" range, 0.5" span, N.C. outputs

The SM6X7A-A08-01 and SM6X7A-A08-11 models have higher gain and can sense a wide variety of standard, rectangular labels.

The SM6X7A-A08-02 and SM6X7A-A08-12 are recommended for labels where any of the following conditions may exist:

- interfering edges
- embossing or printing
- small labels with a fine pitch (less than 1/2" wide)
- perforations in the material on which the labels are affixed

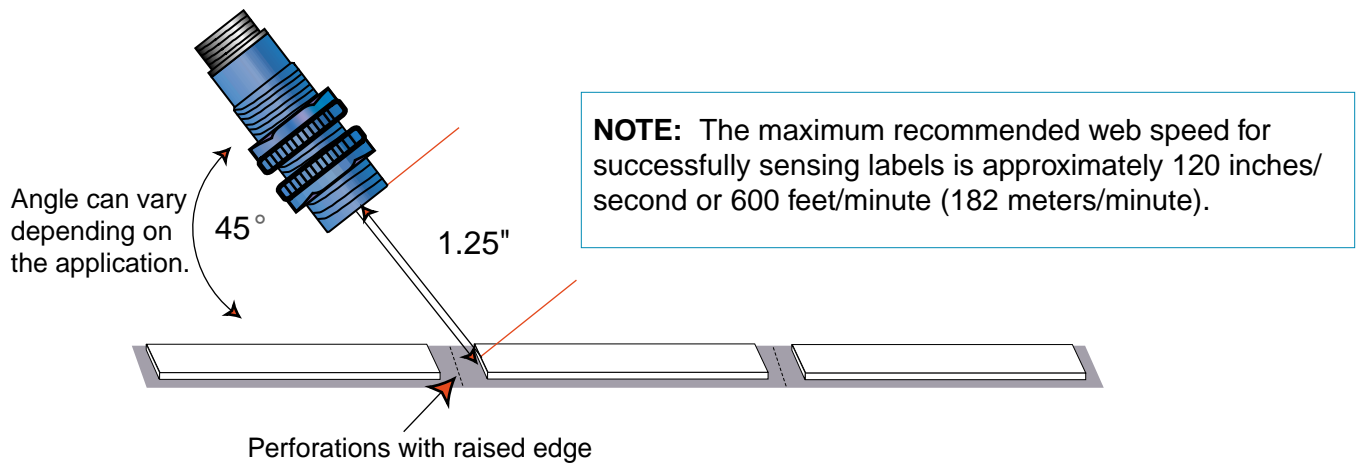

Another sound solution from... **The World Leader in Ultrasonic Sensing.**