

MICROSONIC® Remote Thru-beam Sensors

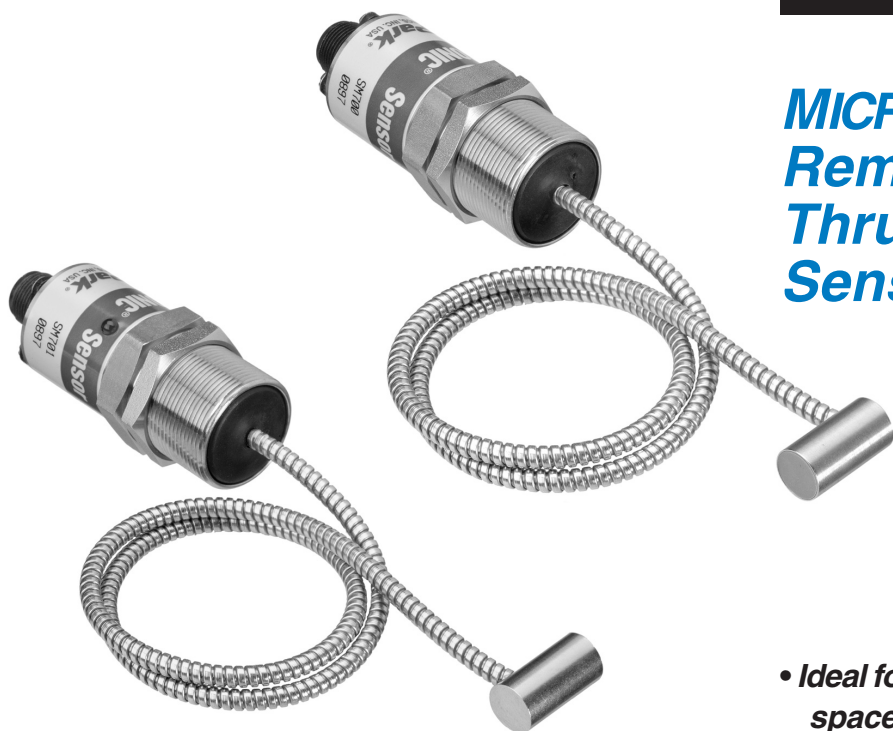

MICROSONIC® remote ultrasonic sensors put precise, thru-beam sensing in hard-to-reach areas

Utilizing the same world-leading ultrasonic sensing technology built into the SM100 series of MICROSONIC® thru-beam sensors, the SM700 series of remote thru-beam sensors takes the accurate detection of objects almost anywhere. Stainless steel armor cables, available in three different lengths, 508 mm (20"), 1016 mm (40") and 1270 mm (50"), link selected standard SM100 series thru-beam transmitters and receivers with the remote stainless steel probes. Designed for extremely tight areas where it is either difficult or impossible to mount and use the SM100 series sensors, these remote sensors have right-angle style probes to further facilitate thru-beam setup and operation.

Unlike photoelectrics, these stainless steel remote sensors are virtually unaffected by splashing food, caustic cleaning solutions, frequent high-pressure wash-downs, humidity, changing light conditions or colors, dust, and ambient noise. The rugged sensors need no maintenance and

require no sensitivity adjustments to compensate for inconsistent product materials.

Response times, ranging from 4 ms down to 0.6 ms, make the MICROSONIC® Model SM700 series of remote thru-beam sensors particularly effective in critical, high-speed, machine process applications. These applications include: double sheet (tissue) detection, film and web hole detection, lead-edge gating, edge-guide monitoring, and transparent object detection.

The 12 to 24 VDC circuitry and output signal make these sensors directly compatible with many programmable logic controllers, computers, and other logic control systems.

- **Ideal for limited spaces**
- **High repeatability and reliability**
- **Self contained**
- **Sensing range 381 mm (15")**
- **Meets NEMA 4X (indoor use only)/ IP67 standards**

Operation

The MICROSONIC® sensors are continuous-wave devices that consist of an ultra-high-frequency transmitter and receiver positioned opposite each other, illustrated at right, at a distance of up to 381 mm (15"). During operation, the transmitter sends a continuous ultrasonic beam which is picked up by the receiver. When an object of any material or shape passes between the transmitter and receiver and breaks the beam, object presence is detected and the output of the receiver switches.

With all circuitry compactly sealed in the stainless steel transmitter and receiver probes, the MICROSONIC® sensors boast a narrow, constant, high-frequency sonic beam for high sensing resolution.

The thru-beam sensing mode is set up by mounting the sensors on the same axis opposite each other as shown in Figure 1. The distance (range) between the transmitter face and receiver face can be up to 381 mm (15").

Positioning of the transmitter and receiver for operation is extremely important for the reliable detection of objects, particularly small ones. As the figure also shows, the width of the transmitted sound beam initially expands at a rate of 10 degrees (5 degrees each side of the common axis) as the distance between the transmitter and receiver increases. This means that if the distance between the transmitter and receiver is too great and the object is too small, it is possible for the beam to "wrap around" the object enough to not cause the receiver output to switch, as shown in Figure 2.

Therefore, reliable detection of small objects is achieved when the objects are allowed to pass near the face of either the transmitter or receiver. This may also be achieved by moving the probes closer together as shown in Figure 3.

Where sensing distances are adversely affected as the environment becomes more contaminated, the MICROSONIC® sensors remain constant under adverse conditions where other sensor types fail.

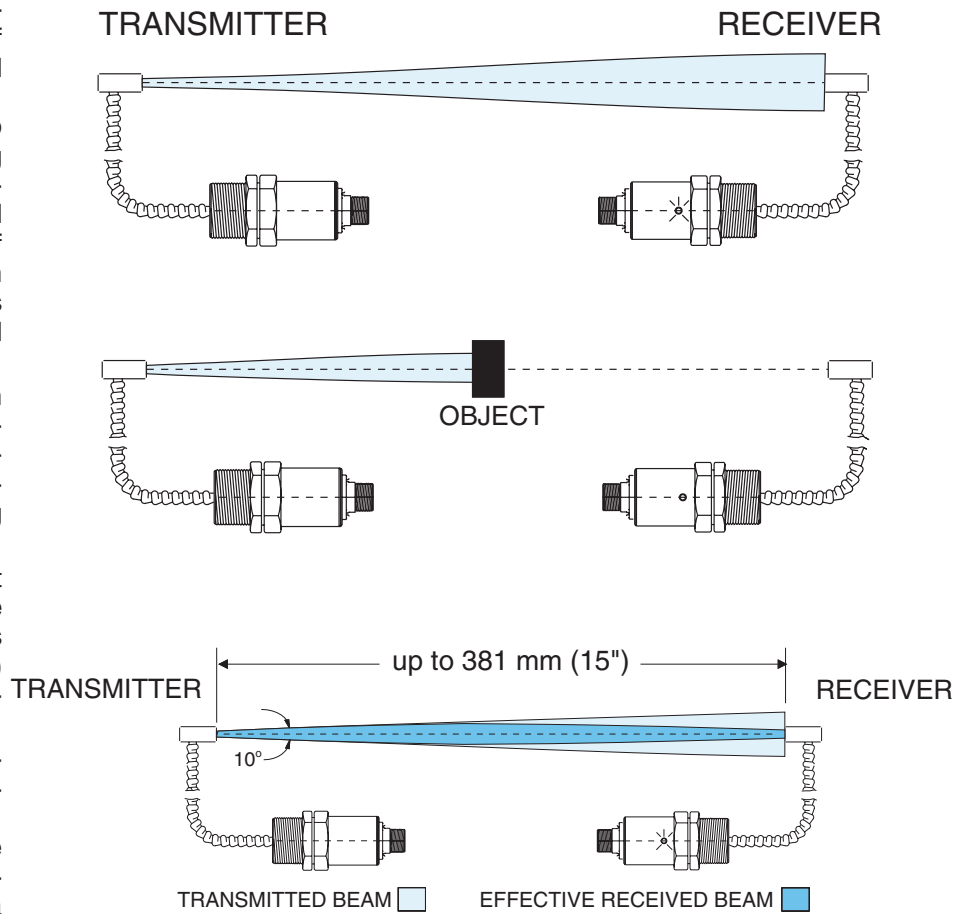

Figure 1, Thru-beam Pattern and Range

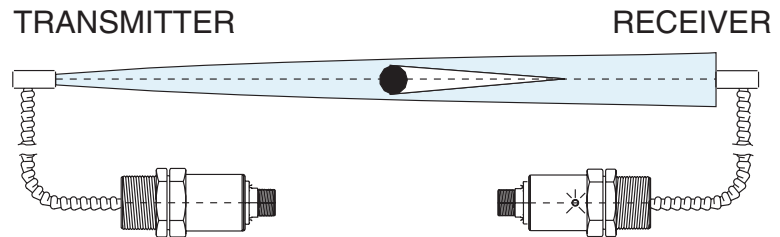

Figure 2

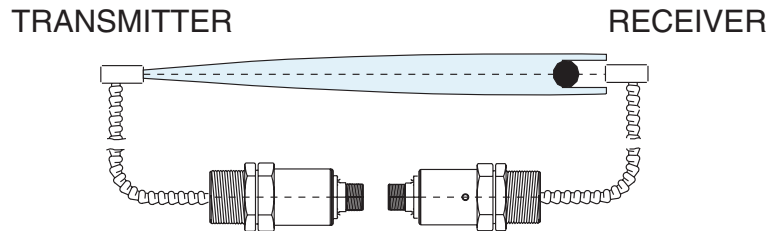

Figure 3

Mounting Accessories

The Model SM700 series remote thru-beam sensors should be mounted in brackets that allow them to be adjusted for proper alignment on the same axis.

Hyde Park offers the Model AC201 stainless, right-angle, single-thru-beam-sensor, mounting bracket and the Model AC213 stainless and Teflon, remote sensing probe mounting bracket which are illustrated, with dimensions, on Page 5-28.

Electrical Wiring

Cable Style

Remote Transmitter Models, Standard Cable Length 3 m (10')
SM701, 701R4, 701R5

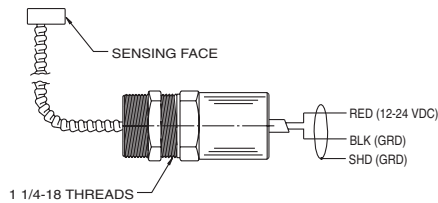

Remote Receiver Models, Standard Cable Length 3 m (10')

SM751, 755, 756, 756R4, 759

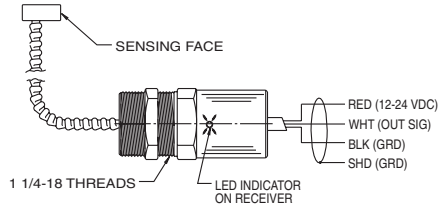

Quick-disconnect (Amphenol) Style*

Remote Transmitter Models with Model AC100 Amphenol, 2-conductor, 3 m (10') Mating Connector Cable: SM700, 705

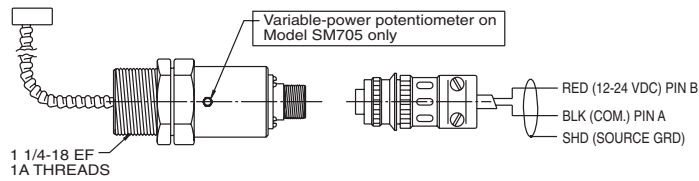

Remote Receiver Models with Model AC150 Amphenol, 3-conductor, 3 m (10') Mating Connector Cable: SM750, 754, 757, 758

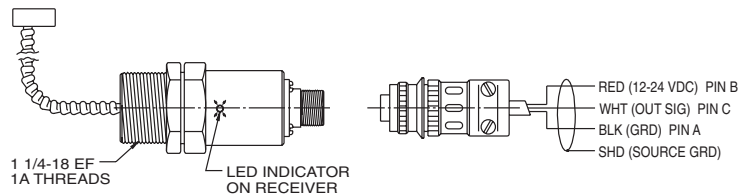

* Use Belden Cable No. 8423 and No. 9154 to extend receiver and transmitter cable length, respectively. Maximum recommended cable length is 152 m (500").

Quick-disconnect (Watertight) Style

Remote Transmitter Models with Model AC107, 7/8-16 mini, 2-conductor, 4 m (12') Mating Connector Cable SM700WTC, 705WTC

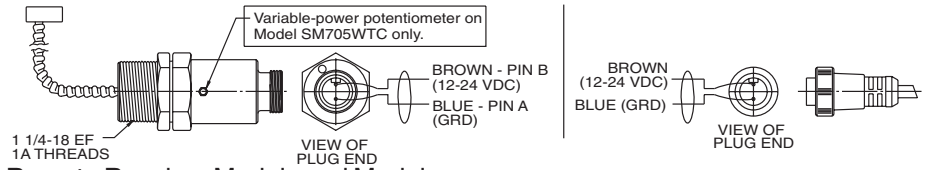

Remote Receiver Models and Model AC108, 7/8-16 mini, 3-conductor, 4 m (12') Mating Connector Cable SM750WTC

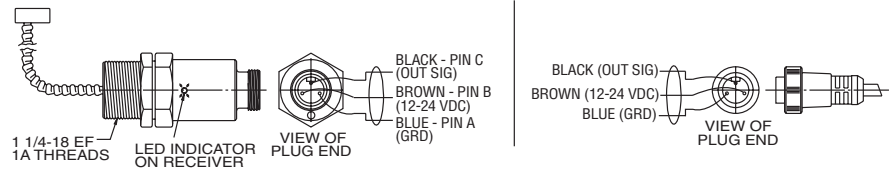

Receiver Outputs

NPN SINKING*

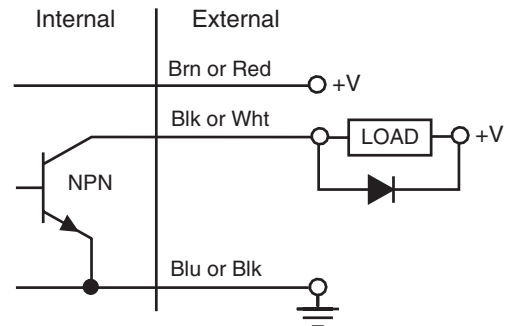

PNP SOURCING*

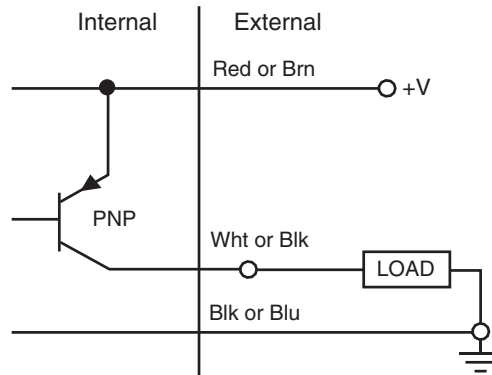

* Cable conductor colors vary, dependent upon the sensor model number.

Dimensions

Cable Style

Remote Transmitter Models: SM701, 701R4, 701R5

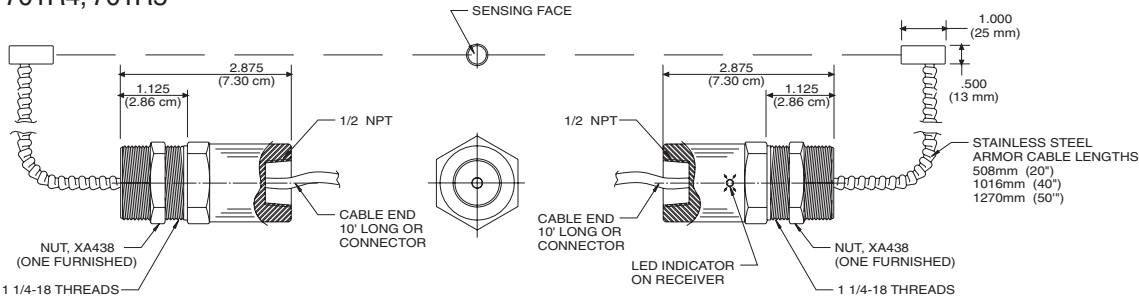

Quick-disconnect (Amphenol) Style

Remote Transmitter Models: SM700, 705

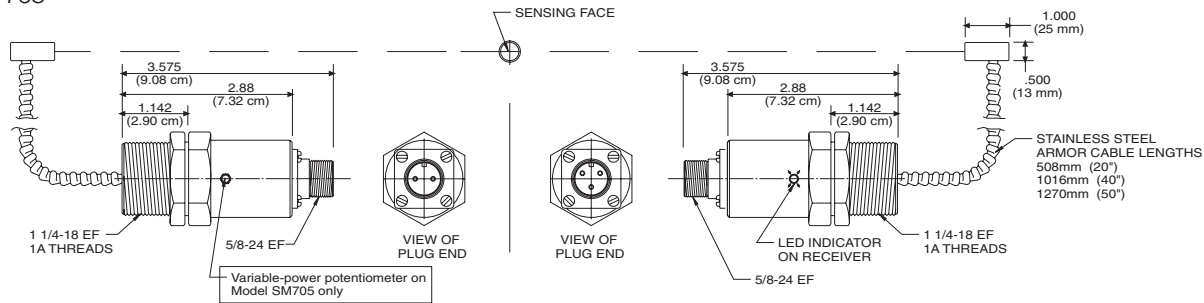

Remote Receiver Models: SM751, 755, 756, 756R4, 759

Quick-disconnect (Watertight) Style

Remote Transmitter Models: SM700WTC, 705WTC

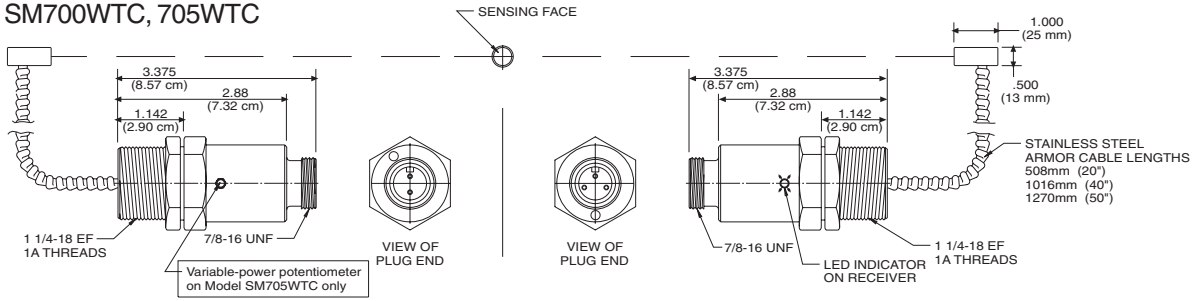

Remote Receiver Models: SM750, 754, 757, 758

Remote Receiver Model: SM750WTC

Mounting Accessories

Model AC201, Stainless, right-angle, single-thru-beam-sensor, mounting bracket, slotted for adjustment

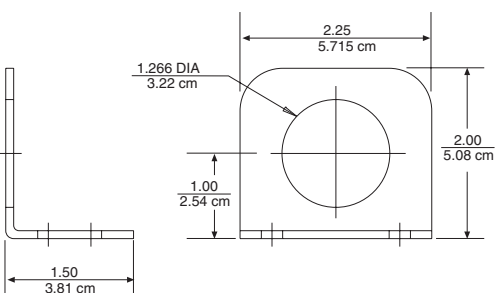

Model AC213, Stainless and Teflon, remote sensing probe mounting bracket

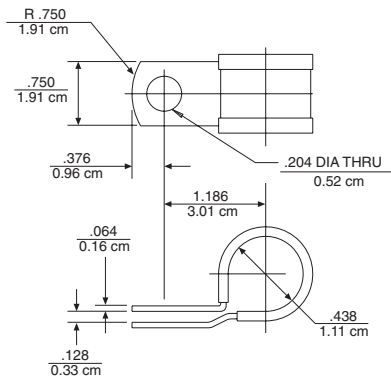

General Specifications

Sensing

Range: 381 mm (15")
Sonic Frequency: 180 kHz
Minimum-size Detection: 9.5 mm (0.375") with object close to sensor
Repeatability: 0.30 mm (0.012") max.

Power Requirements

Supply Voltage: 12 to 24 VDC \pm 10%, regulated supply
Current Consumption: 60 mA max. (excluding load) per set
Power Consumption: 1.2 W max. (excluding load) @ 15 VDC per set

Output

NPN Sinking: 0 to 50 V, max.
Maximum on state voltage 0.2 V @ 100 mA
PNP Sourcing: 100 mA @ 24 VDC, max.
Receiver red LED "ON" when beam is received

Response Time

"On" 0.6 ms or 4 ms
(Model dependent - see selection chart)
"Off" 0.6 ms or 4 ms
(Model dependent - see selection chart)

Indicators

Transmitter: None
Receiver:
Red LED: Illuminated when sonic energy is received, regardless of output state.

Connections

Cable Style Models:
Transmitter: 305 cm (10'), 20 AWG, foil shield, lead-free, PVC jacket, 2-conductor
Receiver: 305 cm (10'), 22 AWG, foil shield, lead-free, PVC jacket, 3-conductor
Connector Style Models:
Amphenol (nonwatertight) quick-disconnect style models:
Model AC100, Transmitter:
305 cm (10'), 20 AWG, foil shield, lead-free, PVC jacket, 2-conductor
Model AC150, Receiver:
305 cm (10'), 22 AWG, foil shield, lead-free, PVC jacket, 3-conductor
Watertight (WTC) quick-disconnect style models:
Model AC107, Transmitter:
7/8-16 mini, 4 m (12'), 18 AWG, 2-conductor
Model AC108, Receiver:
7/8-16 mini, 4 m (12'), 18 AWG, 3-conductor

Protection

Power Supply: ESD
Outputs: ESD

Environmental

Operating Temperature Range:
0° to 60°C
Storage Temperature Range: -40° to 100°C (-40° to 212°F)
Operating Humidity: 100%
Protection Ratings:
Cable Style: NEMA 4X (indoor use only), IP67
Amphenol Quick-disconnect: NEMA 1
Watertight Quick-disconnect: NEMA 4X (indoor use only), IP67
Chemical Resistance: Resists most acids and bases, including most food products. Polypropylene transducer face is available to provide resistance to corrosive chemicals, solvents, and steam.

Construction

Housing: Shock and vibration resistant
Case: Stainless steel
Remote Cable: Stainless steel armor
Transducer Face: silicone rubber, standard
Sensor Cables: Nontoxic PVC jacket
LED: Polycarbonate

Accessories

Model AC100, 2-conductor, transmitter connector cable, 3 m (10'), for all SM700 series Amphenol connector-style transmitters
Model AC107, Straight, 7/8-16 mini, 2-pin, 2 conductor, mating connector cable, 4 m (12'), for all SM700 series watertight, connector-style, transmitters
Model AC108, Straight, 7/8-16 mini, 3-pin, 3 conductor, mating connector cable, 4 m (12'), for all SM700 series watertight, connector-style receivers
Model AC150, 3-conductor, receiver connector cable, 3 m (10'), for all SM700 series Amphenol connector-style receivers
Model AC160, Cable grip for all cable-style, thru-beam sensors
Model AC201, Stainless, right-angle, single-thru beam-sensor, mounting bracket, slotted for adjustment
Model AC213, Stainless and Teflon, remote sensing probe, mounting bracket

See page 7-1 for accessory photos.

Transmitter Selection Chart

SM700 Series MICROSONIC® Remote Thru-Beam

Transmitter Model No.	Receiver Model No.	Power Version	Connection Style	NEMA Rating*	Transmitter/Receiver Housing	Sensing Range	Remote Armor Cable	Remarks
SM700•	SM750	12-24VDC	Quick Disconnect		Stainless	381mm(15")		Amphenol connector
	SM754	12-24VDC	Quick Disconnect		Stainless	381mm(15")		Amphenol connector
	SM757	12-24VDC	Quick Disconnect		Stainless	381mm(15")		Amphenol connector
	SM758	12-24VDC	Quick Disconnect		Stainless	381mm(15")		Amphenol connector
SM701•	SM751	12-24VDC	305cm(10') cable	4X, IP67	Stainless	381mm(15")		
	SM755	12-24VDC	305cm(10') cable	4X, IP67	Stainless	381mm(15")		
	SM756	12-24VDC	305cm(10') cable	4X, IP67	Stainless	381mm(15")		
	SM754 R4	12-24VDC	305cm(10') cable	4X, IP67	Stainless	381mm(15")		
	SM759	12-24VDC	305cm(10') cable	4X, IP67	Stainless	381mm(15")		
SM701 R4	SM751	12-24VDC	305cm(10') cable	4X, IP67	Stainless	381mm(15")	1016mm(40")	
	SM755	12-24VDC	305cm(10') cable	4X, IP67	Stainless	381mm(15")		
	SM756	12-24VDC	305cm(10') cable	4X, IP67	Stainless	381mm(15")		
	SM756 R4	12-24VDC	305cm(10') cable	4X, IP67	Stainless	381mm(15")		
	SM759	12-24VDC	305cm(10') cable	4X, IP67	Stainless	381mm(15")		
SM701 R5	SM751	12-24VDC	305cm(10') cable	4X, IP67	Stainless	381mm(15")	1270mm(50")	
	SM755	12-24VDC	305cm(10') cable	4X, IP67	Stainless	381mm(15")		
	SM756	12-24VDC	305cm(10') cable	4X, IP67	Stainless	381mm(15")		
	SM756 R4	12-24VDC	305cm(10') cable	4X, IP67	Stainless	381mm(15")		
	SM759	12-24VDC	305cm(10') cable	4X, IP67	Stainless	381mm(15")		
SM705	SM750	12-24VDC	Quick Disconnect		Stainless	381mm(15")		Variable power, Amphenol connector
	SM754	12-24VDC	Quick Disconnect		Stainless	381mm(15")		Variable power, Amphenol connector
	SM757	12-24VDC	Quick Disconnect		Stainless	381mm(15")		Variable power, Amphenol connector
	SM758	12-24VDC	Quick Disconnect		Stainless	381mm(15")		Variable power, Amphenol connector

• = Most commonly stocked sensors

* NEMA Rating for indoor use only

All possible sensor configurations are not listed here.

Receiver Selection Chart

SM700 Series (cont.) MICROSONIC® Remote Thru-Beam

Receiver Model No.	Transmitter Model No.	Power Version	Connection Style	NEMA Rating*	Transmitter/Receiver Housing	Sensing Range	Remote Armor Cable	Response Time	Remarks (Outputs N.O. unless noted)
SM750•	SM700	12-24VDC	Quick Disconnect		Stainless	381mm(15")		On 4ms, Off 4ms	NPN Sinking, Amphenol connector
	SM705	12-24VDC	Quick Disconnect		Stainless	381mm(15")		On 4ms, Off 4ms	NPN Sinking, Amphenol connector
SM751•	SM701	12-24VDC	305cm(10') cable	4X, IP67	Stainless	381mm(15")		On 4ms, Off 4ms	NPN Sinking
	SM701 R4	12-24VDC	305cm(10') cable	4X, IP67	Stainless	381mm(15")		On 4ms, Off 4ms	NPN Sinking
	SM701 R5	12-24VDC	305cm(10') cable	4X, IP67	Stainless	381mm(15")		On 4ms, Off 4ms	NPN Sinking
SM754	SM700	12-24VDC	Quick Disconnect		Stainless	381mm(15")		On .6ms, Off .6ms	NPN Sinking, Amphenol connector
	SM705	12-24VDC	Quick Disconnect		Stainless	381mm(15")		On .6ms, Off .6ms	NPN Sinking, Amphenol connector
SM755	SM701	12-24VDC	305cm(10') cable	4X, IP67	Stainless	381mm(15")		On .6ms, Off.6ms	NPN Sinking
	SM701 R4	12-24VDC	305cm(10') cable	4X, IP67	Stainless	381mm(15")		On .6ms, Off.6ms	NPN Sinking
	SM701 R5	12-24VDC	305cm(10') cable	4X, IP67	Stainless	381mm(15")		On .6ms, Off.6ms	NPN Sinking
SM756	SM701	12-24VDC	305cm(10') cable	4X, IP67	Stainless	381mm(15")		On 4ms, Off 4ms	PNP Sourcing
	SM701 R4	12-24VDC	305cm(10') cable	4X, IP67	Stainless	381mm(15")		On 4ms, Off 4ms	PNP Sourcing
	SM701 R5	12-24VDC	305cm(10') cable	4X, IP67	Stainless	381mm(15")		On 4ms, Off 4ms	PNP Sourcing
SM756 R4	SM701	12-24VDC	305cm(10') cable	4X, IP67	Stainless	381mm(15")	1016mm(40")	On 4ms, Off 4ms	PNP Sourcing
	SM701 R4	12-24VDC	305cm(10') cable	4X, IP67	Stainless	381mm(15")		On 4ms, Off 4ms	PNP Sourcing
	SM701 R5	12-24VDC	305cm(10') cable	4X, IP67	Stainless	381mm(15")		On 4ms, Off 4ms	PNP Sourcing
SM757	SM700	12-24VDC	Quick Disconnect		Stainless	381mm(15")		On .6ms, Off.6ms	PNP Sourcing, Amphenol connector
	SM705	12-24VDC	Quick Disconnect		Stainless	381mm(15")		On .6ms, Off.6ms	PNP Sourcing, Amphenol connector
SM758	SM700	12-24VDC	Quick Disconnect		Stainless	381mm(15")		On 4ms, Off 4ms	PNP Sourcing, Amphenol connector
	SM705	12-24VDC	Quick Disconnect		Stainless	381mm(15")		On 4ms, Off 4ms	PNP Sourcing, Amphenol connector
SM759	SM701	12-24VDC	305cm(10') cable	4X, IP67	Stainless	381mm(15")		On .6ms, Off.6ms	PNP Sourcing
	SM701 R4	12-24VDC	305cm(10') cable	4X, IP67	Stainless	381mm(15")		On .6ms, Off.6ms	PNP Sourcing
	SM701 R5	12-24VDC	305cm(10') cable	4X, IP67	Stainless	381mm(15")		On .6ms, Off.6ms	PNP Sourcing

• = Most commonly stocked sensors

* NEMA Rating for indoor use only

All possible sensor configurations are not listed here.

